

**Doppstadt**

# AK SERIES

GRINDER LINE



**BEST SOLUTION. SMART RECYCLING.**

## **CONTINUING WHERE OTHERS STOP.**

The mobile fine shredders of the AK series are the ideal solution for compost or waste wood processors, disposal companies or the operators of biogas plants. Regardless of whether you process waste wood, RDF, offcuts, green waste, bio-waste, manure or pre-shred tree roots, the load-sensing infeed ensures a high throughput with maximum efficiency.

You can easily combine the AK series with a pre-shredder or a drum screening machine. This results in a powerful complete solution for mechanical/biological treatment, biomass or refuse-derived fuels.



### **SMART SHREDDING WITH OUR GRINDER LINE.**

#### **RUGGED SYSTEMS.**

All machines of Doppstadt's GRINDER LINE shred efficiently and reliably. They can handle substantial foreign objects, easy-to-use and easily accessible. That minimizes your maintenance costs and the downtimes on your machine. If you are not able to solve a problem on your own, Doppstadt Service will be on site in no time at all.

#### **PROFITABLE RESULTS.**

With the AK series, you can make your recycling processes efficient and profitable thanks to its great adaptability and mobility. The high throughput speeds up the flow of materials so that you are able to complete your jobs quickly. The processed materials are available in high quality for sale or for thermal utilization.

*AK series with  
waste wood as example*



## **HIGH TECH COMBINED WITH HEAVY DUTY.**

- Powerful engines with the latest exhaust technology deliver the performance that you need.
- The Twin Drive combines performance with economy and thus increases your efficiency.
- The shredding concept ensures use in a wide variety of applications, even with substantial foreign objects.
- Operating time is also increased thanks to quick and easy access for maintenance and tool changes.
- As a result, the high-quality flail tips with patented Dopp-Lock® fastening technology can be replaced very easily and quickly.

## **VERSATILITY IN USE.**

Like all Doppstadt machines, the models of the AK series can be expanded and are thus very versatile. Every machine can be precisely configured to your requirements. For instance, you can adapt the shredding system, selecting an additional removal of the FE-fraction at the rear conveyor or increasing the hopper's capacity in order to be able to feed more material per loading cycle. If you choose a model equipped with a track-laying chassis, the machine is sure-footed and safe even over rough terrain.



## **WE HAVE LISTENED TO YOU CAREFULLY.**

From ease of maintenance and increased performance through to new decentralized electrical system, we have further developed the AK series in accordance with your requirements. It is the special solutions from Doppstadt that help you and make your work better every day.

## **FOOT SWITCHES ENSURE SAFE OPERATION.**

To be able to operate the AK even more efficiently, you can optionally equip your shredder with foot switches for the radio remote control. On the one hand, this enables the AK to move forward, for instance, when creating compost windrows, and on the other hand, to manually reverse the infeed.

The use of foot switches is especially reasonable when you need to maintain full control over demanding materials. Both hands remain free. And you can fully concentrate on controlling the loading vehicle.

### **1 EFFECTIVE COOLING**

The fan's speed is controlled intelligently, and the engine compartment is optimally cooled with fresh air. Long periods of use are not a problem thanks to the fan's reverse feature. In addition to that, the swivelling cooler is easy to access for further maintenance.

### **2 POWERFUL ENGINE PERFORMANCE**

The new EU Stage V engines deliver a higher torque. For maximum service life, the supercharged air / air intake piping, the exhaust system and the AGN box are made entirely of stainless steel and are insulated.

### **3 EASY TO USE**

The central multifunctional display is used to configure the machine and monitor the data. You can control the AK easily using the remote control while sitting on the loading vehicle.

### **4 FULL MOBILITY**

Thanks to the optional hydraulic drive, you can simple move the wheeled machine to create, for instance, a compost windrow.

### **5 EFFICIENT DRIVE TRAIN**

Hydraulically supported, the drive belt remains at an ideal tension even when the loads change. As a result, the power is efficiently transferred from the engine to the flail drum, significantly reducing the wear and tear on the drive train.

### **6 UNIFORM FLOW OF MATERIAL**

Scraper floor and infeed roller draws the material into the shredding unit evenly. This allows you to work without tiring even on long days.





## **MORE THROUGHPUT WITH THE TWIN DRIVE.\***

- Continuous shredding: The control of the material infeed is load-sensing.
- Increased throughput: You are able to process more material per liter of fuel.
- Uniform flow of material in every application: The scraper floor and infeed roller can be adjusted independently of the speed.
- Reduced workload in daily routine: The machine reverses automatically and in relation to output load.
- High reliability and easy maintenance: You do not have to control the chain drive.



### **7 LESS DUST**

The damping facility (optional) significantly reduce occurrence of dust if necessary.

### **8 MAXIMUM GRINDING PERFORMANCE**

The large-sized flail drum with its flywheel mass of approx. 2.5 m. ton and free-swinging flail tips shred materials thanks to their high impact power.

The rugged rotor can easily handle even substantial foreign materials. The baffle plate in different configurations supports the shredding process adapted to your applications.

### **9 PRECISE FINE SHREDDING**

You can determine the desired size of the output material with the aid of fine-shredding baskets, which have a mesh size between 30 and 400 mm.

### **10 FAST REFITTING**

The rear conveyor, which can be lowered to the ground, (optional) ensures quick access for maintenance and refitting. A neodymium magnetic pulley that can be optionally integrated in the conveyor and an overbelt magnet removes FE metals from the material.

### **SMART CONNECTION.**

With the cloud-based Doppstadt telematics solution, you can keep an eye on your system at all times. The system provides you with all machine parameters in real time via GPS.

\*Except for AK 315:

## **REDUCING UNNECESSARY DOWNTIME.**

All models of the AK series are equipped with large doors and maintenance hatches, making routine maintenance much easier for your operators and workshop technicians. You will be impressed by how quickly your machine is ready to operate again.

For instance, the machine's rear conveyor can be lowered almost completely to the ground (optional). This means that not only is the flail drum easy to access but also also the tools, baffle plates and shredding baskets. The baskets can be replaced within only 15 minutes.

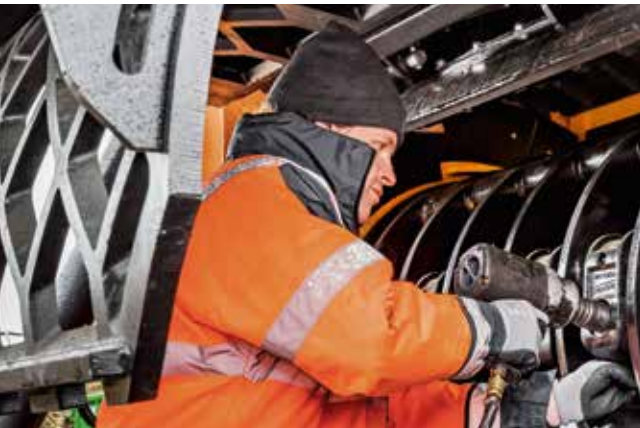

*"The flail tips can be quickly changed on site. This makes my daily work on the machine easier."*

*(Michael Steffen,  
Application Engineer at Doppstadt Calbe GmbH)*

## **REMOTE DIAGNOSIS SAVES VALUABLE TIME.**

Providing world-class service means: Wherever you are working, we are at your side. The AK series has telematics monitoring and remote diagnostics systems.

As a result, Doppstadt service technicians can quickly assist you with malfunctions or repairs – even without always having to be on site themselves.





## YOU WORK MORE EFFICIENTLY WHEN EVERYTHING SUITS YOUR NEEDS.

The more precisely your tool matches the material, the more convincing the work result. In the AK series, you will find extensive equipment options, with which you can adapt your machine exactly to the operating conditions. Choose from a wide variety of flail tips, rear baskets and deflector plates. Green waste in the morning, waste wood in the afternoon – you can switch to the right basket in no time at all.



### SHREDDER EQUIPMENT OPTIONS

1 SHREDDING BASKET	2 BAFFLE PLATE	3 FLAIL DRUM	4 FLAIL TIP
<ul style="list-style-type: none"> <li>■ Diamond rear basket: Different mesh sizes from 30 to 400 mm</li> <li>■ Strip basket: specifically for green waste</li> <li>■ Rear basket 3D waste wood: specifically for waste wood, different mesh sizes from 80 to 300 mm</li> <li>■ Rear basket 3D mulch: specifically for small particle sizes, for waste wood and biomass, different mesh sizes from 50 to 100 mm</li> </ul>	<ul style="list-style-type: none"> <li>■ Toothed</li> <li>■ Counter blade</li> <li>■ Counter blade reinforced</li> <li>■ Smooth</li> <li>■ Counter blade with row of teeth</li> </ul>	<ul style="list-style-type: none"> <li>■ For AK 315: fixed teeth, freely oscillating flails, new additional hard surfacing</li> <li>■ As of AK 565: freely oscillating flails</li> </ul>	<ul style="list-style-type: none"> <li>■ Chisel</li> <li>■ Carbide Plus</li> <li>■ Bear paw with HM</li> <li>■ Bear paw with HM 2R</li> </ul>

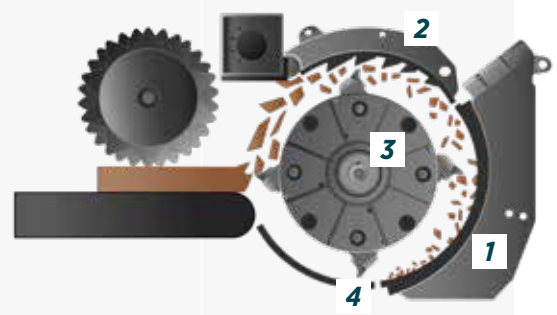





*Learn more about Doppstadt's shredding technology, such as the AK 640 K at Zeyn.*

*"Unlike before, it is now easier to change the basket quickly within 15 minutes thanks to the trapezoidal system."*

*(Heiko Barwich, Machine operator, at Zeyn)*

**FREQUENTLY IMITATED.  
NEVER MATCHED.**

The flail drum forms the heart of the machine. The sophisticated and unique shredding principle of the flail drum enables you to break down the material to a particular high degree. Ferrous parts are cleanly separated from the waste wood, the composting of green waste is significantly accelerated.

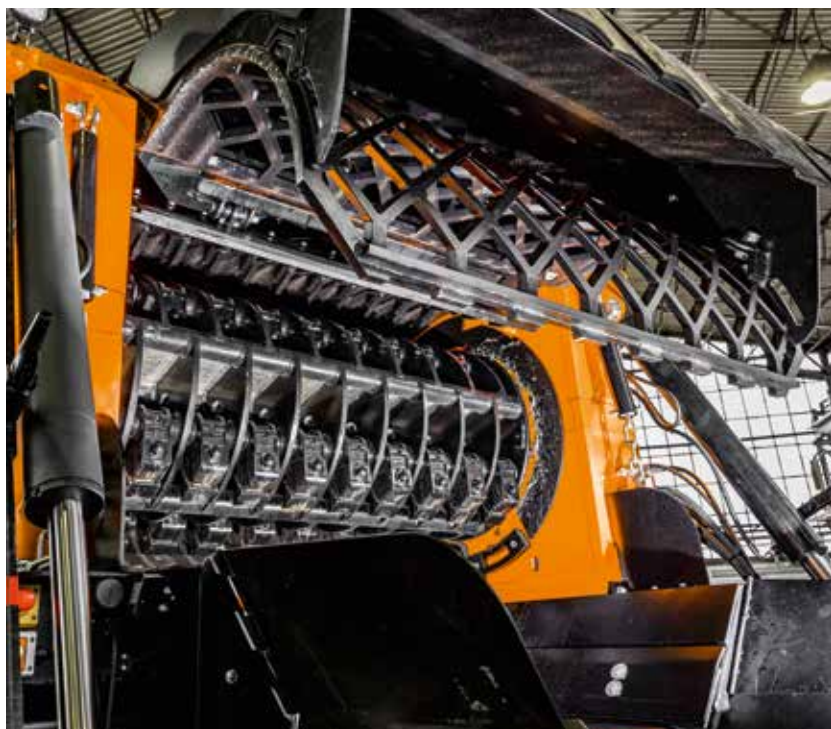

## **YOU WILL FIND EXACTLY THE RIGHT MACHINE.**

In the AK series, you will find the machine that meets your high standards. The mobile, high-speed shredders are available in different sizes and performance dimensions. Our experts will be happy to advise you to ensure that you have the machine that suits your recycling requirements at your disposal. The range extends from the smallest, high-performance shredder AK 315, the all-purpose shredder AK 565 through to the flagship AK 640 SA, which you can use to move mountains day after day.



### **GRINDER LINE**



**1** **AK 315**  
The compact for more perspectives in recycling.



**2** **AK 565**  
The capable contractor for more performance – even mobile.



**3** **AK 640 K**  
The colossus for powerful performance even off-road.



**3** **AK 640 SA**  
The mobile flagship for really major jobs.



**2 AK 565 PLUS**  
The flexible for more variety of features.



**2 AK 565 K**  
The offroader for full throughput off the beaten path.



**PERFORMANCE PARAMETERS**

- 1** Small material streams up to 35,000 m. ton/yr
- 2** Average material streams up to 60,000 m. ton/yr
- 3** Large material streams up to 90,000 m. ton/yr

*"Large, powerful and still mobile. The AK 640 SA is unstoppable, just like its smaller sibling, which shares many technical refinements with the flagship."*

*(Jan Hauschild, Project manager, Doppstadt)*

*Learn more about Doppstadt's solutions and their advantages.*



Exhaust system



Hydraulic



Control system



	<b>AK 315</b>	<b>AK 565</b>	<b>AK 565 K</b>
Chassis	2-axle trailer	2-axle trailer	Track-laying chassis
<b>DIMENSIONS</b>			
Overall weight	16,000 kg	19,000 kg	29,000 kg
<b>WORKING POSITION</b>			
Length	12,890 mm	11,780 mm / 13,250 mm	13,750 mm
Width	2,130 mm	2,500 mm	3,000 mm
Height	3,550 mm	3,000 mm / 4,150 mm	5,090 mm / 5,290 mm (with off-road chassis)
<b>TRANSPORT DIMENSIONS</b>			
Length	9,240 mm	9,770 mm / 9,850 mm	8,670 mm
Width	2,130 mm	2,500 mm	3,000 mm
Height	3,080 mm	3,960 mm / 3,850 mm	3,390 mm / 3,500 mm (with off-road chassis)
<b>DRIVE</b>			
Engine type	Diesel	Diesel	Diesel
Make	MTU 6R 1000	MTU 6R 1300	MTU 6R 1300
Emission standard	Stage V / EPA Tier 4f / EIIIA	Stage V / EPA Tier 4f / EIIIA	Stage V / EPA Tier 4f / EIIIA
Nominal output	230 kW / 310 HP	390 kW / 530 HP	390 kW / 530 HP
Torque	1,300   1,250 (EIIIA) at 1,200-1,600 rpm	2,600   2,460 (EIIIA) at 1,300 rpm	2,600   2,460 (EIIIA) at 1,300 rpm
Tank capacity	300 L	450 L / 600 L* * Optional.	600 L
<b>FLAIL DRUM</b>			
Number of flails / teeth	16/28	36	36
Width	1,470 mm	1,750 mm	1,750 mm
Diameter	900 mm	1,120 mm	1,120 mm
Speed	1,140-1,320 rpm (depending on the engine's speed)	850-1,000 rpm (depending on the engine's speed)	850-1,000 rpm (depending on the engine's speed)
<b>FEED HOPPER</b>			
Infeed height	421 mm	538 mm	538 mm
Filling width	2,730 mm	2,670 mm	2,670 mm
Loading height	2,050 mm	2,180 mm	2,230 mm / 2,430 mm (with offroad chassis)
<b>DISCHARGE BELT</b>			
Length	6,000 mm	4,000 mm / 6,000 mm* * Optional.	7,500 mm
Width	1,500 mm	1,800 mm	1,500 mm
Belt speed	2 m/s	2 m/s	2 m/s
Discharge height	3,550 mm	3,000 mm / 4,150 mm* * Optional.	5,090 mm
<b>OTHER</b>			
Optional equipment	Hydraulic drive, overbelt magnet, neodymium magnet pulley, damping facility, dust and noise suppression hood, central lubrication, hopper extensions, scraper floor chain lubrication, winter package, LED light kits	Hydraulic drive, overbelt magnet, neodymium magnet pulley, damping facility, dust and noise suppression hood, infeed roller clean EBS, central lubrication, hopper extensions, scraper floor chain lubrication, winter package, LED light kits	Overbelt magnet, neodymium magnet pulley, damping facility, dust and noise suppression hood, infeed roller clean EBS, central lubrication, hopper extensions, scraper floor chain lubrication, winter package, LED light kits

	<b>AK 565 PLUS</b>	<b>AK 640 K</b>	<b>AK 640 SA</b>
Chassis	3-axle trailer	Track-laying chassis	3-axle Semi-trailer
<b>DIMENSIONS</b>			
Overall weight	22,000 kg	32,500 kg	32,000 kg
<b>WORKING POSITION</b>			
Length	13,380 mm	15,910 mm	17,380 mm
Width	2,500 mm	3,000 mm	2,530 mm
Height	4,290 mm	5,090 mm / 5,290 mm (with offroad chassis)	5,350 mm
<b>TRANSPORT DIMENSIONS</b>			
Length	9,990 mm	10,020 mm	11,990 mm
Width	2,500 mm	3,000 mm	2,530 mm
Height	3,810 mm	3,390 mm / 3,590 mm (with offroad chassis)	3,650 mm
<b>DRIVE</b>			
Engine type	Diesel	Diesel	Diesel
Make	MTU 6R 1300	MTU 6R 1500	MTU 6R 1500
Emission standard	Stage V / EPA Tier 4f / EIIIA	Stage V / EPA Tier 4f / EIIIA	Stage V / EPA Tier 4f / EIIIA
Nominal output	390 kW / 530 HP	480 kW / 652 HP 460 kW / 625 HP (EIIIA)	480 kW / 652 HP 460 kW / 625 HP (EIIIA)
Torque	2,600   2,460 (EIIIA) at 1,300 rpm	3,100   2,900 (EIIIA) at 1,300 rpm	3,100   2,900 (EIIIA) at 1,300 rpm
Tank capacity	600 L	750 L	900 L
<b>FLAIL DRUM</b>			
Number of flails / teeth	36	36	36
Width	1,750 mm	1,750 mm	1,750 mm
Diameter	1,120 mm	1,120 mm	1,120 mm
Speed	850-1,000 rpm (depending on the engine's speed)	970-1,140 rpm (depending on the engine's speed)	970-1,140 rpm (depending on the engine's speed)
<b>FEED HOPPER</b>			
Infeed height	538 mm	538 mm	538 mm
Filling width	2,670 mm	3,500 mm	5,720 mm
Loading height	2,260 mm	2,220 mm / 2,420 mm (with off-road chassis)	2,420 mm
<b>DISCHARGE BELT</b>			
Length	6,000 mm	7,500 mm	7,500 mm
Width	1,800 mm	1,500 mm	1,500 mm
Belt speed	2 m/s	2 m/s	2 m/s
Discharge height	4,290 mm	5,090 mm	5,350 mm
<b>OTHER</b>			
Optional equipment	Hydraulic drive, overbelt magnet, neodymium magnet pulley, damping facility, dust and noise suppression hood, infeed roller clean EBS, central lubrication, hopper extensions, scraper floor chain lubrication, winter package, LED light kits	Overbelt magnet, neodymium magnet pulley, dust and noise suppression hood, infeed roller clean EBS, central lubrication, hopper extensions, scraper floor chain lubrication, winter package, LED light kits	Hydraulic drive, overbelt magnet, neodymium magnet pulley, dust and noise suppression hood, infeed roller clean EBS, central lubrication, hopper extensions, scraper floor chain lubrication, winter package, LED light kits

## ***BEST SOLUTION. SMART RECYCLING.***

Our innovative solutions have made us a leading supplier and manufacturer of processing technology. Customers in the waste disposal and recycling industry all over the world trust our expertise and benefit from our qualified service every day.

We are always there for you. At the Doppstadt Academy, we develop your team online and offline so that you can fully exploit the performance potential of the machines and make operations even more productive. Added to this are worldwide security of supply, fast on-site repair service and all-round carefree packages within service and maintenance contracts.

Because “every machine is only as good as the service behind it.” (Werner Doppstadt)



**Doppstadt**  
Academy